

Broadband Resistive Power Splitter MODEL 7PS-018

DC – 18.0 GHz

1 WATT

Features

These resistive power splitters are intended for use with RF and wireless applications where one of the two outputs are included in a leveling loop or used as a reference in a ratio system providing an output signal whose source impedance is matched to 50 ohms.

MAXIMUM VSWR	
Frequency (GHz)	VSWR
DC – 18.0	1.30
Max if both output ports are terminated in 50 ohms.	

Specifications

NOMINAL IMPEDANCE: 50Ω

FREQUENCY RANGE: DC TO 18.0 GHz

INSERTION LOSS: (Between input & either output arm): 6 dB nominal, 7.5 dB maximum.

MAXIMUM INPUT POWER: 1.0 watt CW, 1 kilowatt peak (5μsec pulse width, 0.05 duty cycle) maximum (input connector only).

MAXIMUM BALANCE OF POWER DIVISION:

DC – 18.0 GHz	0.15 dB
8.0 – 18.0 GHz	0.20 dB
Typical	0.1 dB

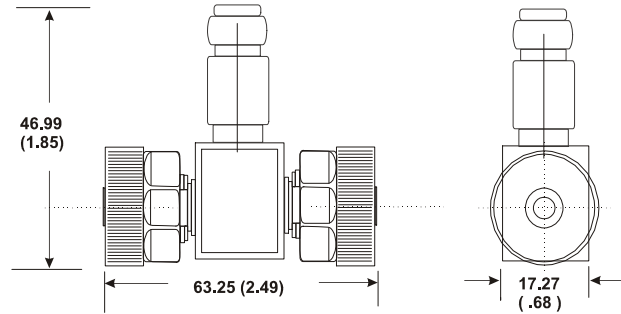

PHYSICAL DIMENSIONS:

PHASE TRAKING: ±2° nominal between output ports

EQUIVALENT OUTPUT SWR: (Port 2 & 3 when in a leveling or ratio system)

DC – 2.0 GHz	1.05
2.0 – 4.0 GHz	1.07
4.0 – 8.0 GHz	1.10
8.0 – 18.0 GHz	1.15

POWER COEFFICIENT: <0.005 dB/dB x W

TEMPERATURE COEFFICIENT: <0.0004 dB/dB x °C

TEMPERATURE RANGE: -55°C to +85 °C

CONSTRUCTION: Nickel plated brass body; stainless steel connectors; gold plated beryllium copper contacts.

CONNECTORS: Type N stainless steel female (input) connector per MIL-STD-348A, interface nondestructively with MIL-PRF-39012 connectors. Precision 7mm (output). Meets or exceeds requirements of IEEE STD 287 and mates with all connectors conforming to design 2 of that standard.

WEIGHT: .17 kg (6 oz) maximum

NOTE: All dimensions are given in mm (inches) and are maximum, unless otherwise specified.



WEINSCHEL ASSOCIATES

TEL: 877.948.8342 / 301.963.4630 ♦ Fax: 301.963.8640

WEB: <http://www.WeinschelAssociates.com>

EMAIL: sales@WeinschelAssociates.com

129

Specification
Subject to change
without notice