

NOTES:  
1.

REVISIONS				
ZONE	REV	DESCRIPTION	DATE	APPROVED
	1	CORRECTED BASE WIDTH DIMENSION	11/21/13	DMH

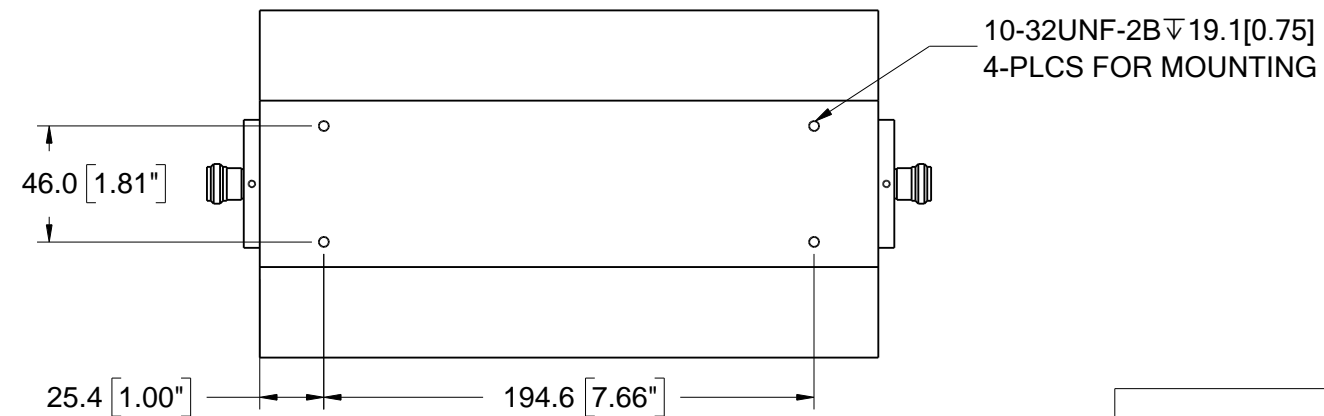
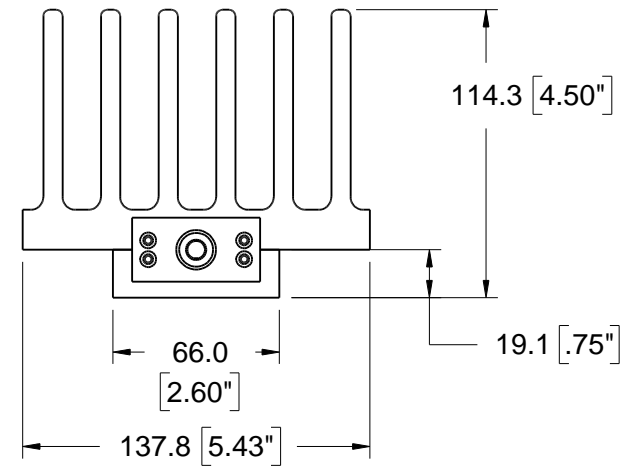
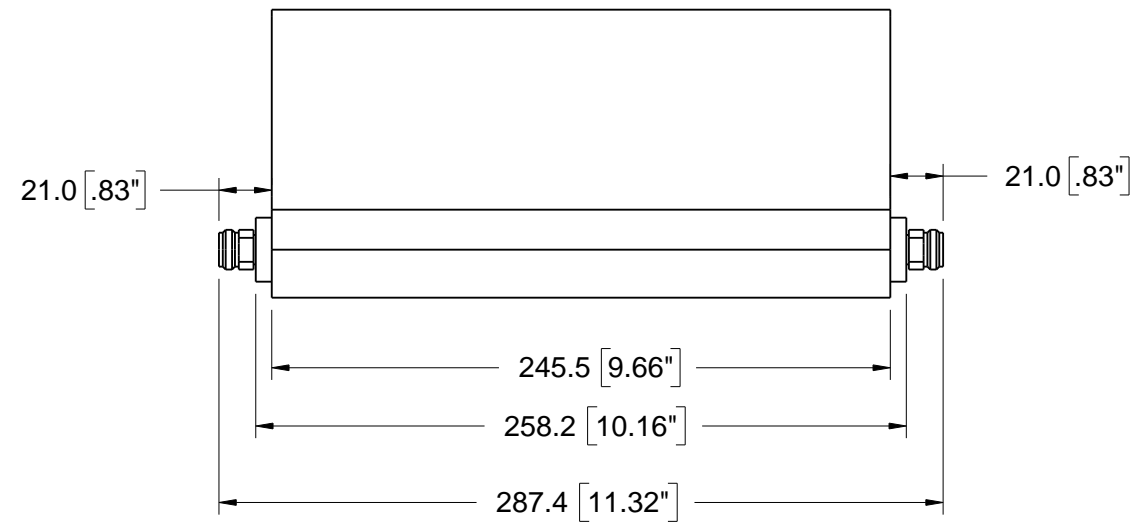

DIMENSIONS IN INCHES 3 PLCS +/- .003 2 PLCS +/- .01 FRACTIONS +/- 1/64 ANGLES +/- 1/2 DEG UNLESS OTHERWISE SPECIFIED	DRAWN D. HEFT	DATE 09/22/08	<b>WEINSCHEL ASSOCIATES</b> 19212 ORBIT DRIVE GAITHERSBURG, MD 20879 <b>OUTLINE DRAWING</b> <b>WA60-xx-33 ATTENUATOR</b>				
	CHECKED						
	MAT'L: NA	QA		SIZE <b>B</b>	FSCM NO. 0H3E9	DWG NO. B	REV 1
	FINISH: NA	APPROVED		SCALE NONE	SHEET 1 OF 1		

PROPERTY OF nVISION INDUSTRIES, INC, COMPANY CONFIDENTIAL